

# AVERY DENNISON MARKETING SPECIFICATION

## HISTORY

THE SUBJECT MATTER DISCLOSED HEREIN EMBODIES PROPRIETARY INFORMATION WHICH IS THE CONFIDENTIAL PROPERTY OF THE AVERY DENNISON CO. NONE OF WHICH SHALL BE COPIED, REPRODUCED, DISCLOSED TO OTHERS, PUBLISHED OR USED IN WHOLE OR IN PART, FOR ANY PURPOSE OTHER THAN THAT FOR WHICH IT IS BEING MADE AVAILABLE WITHOUT THE EXPRESS ADVANCE WRITTEN PERMISSION OF A DULY AUTHORIZED AGENT OF THE COMPANY. THIS DOCUMENT IS THE PROPERTY OF THE AVERY DENNISON CO. AND IS TO BE RETURNED TO THE COMPANY ON DEMAND.

REV.	DATE	DESCRIPTION
Q	10-07-16	ADDED FLAMMABILITY CALL OUT AND SPECIAL CHAR. NOTE. ; CHG ORIGINAL DIM 5 TO REF. AND CHG DIM 6 TO BE DIM 5

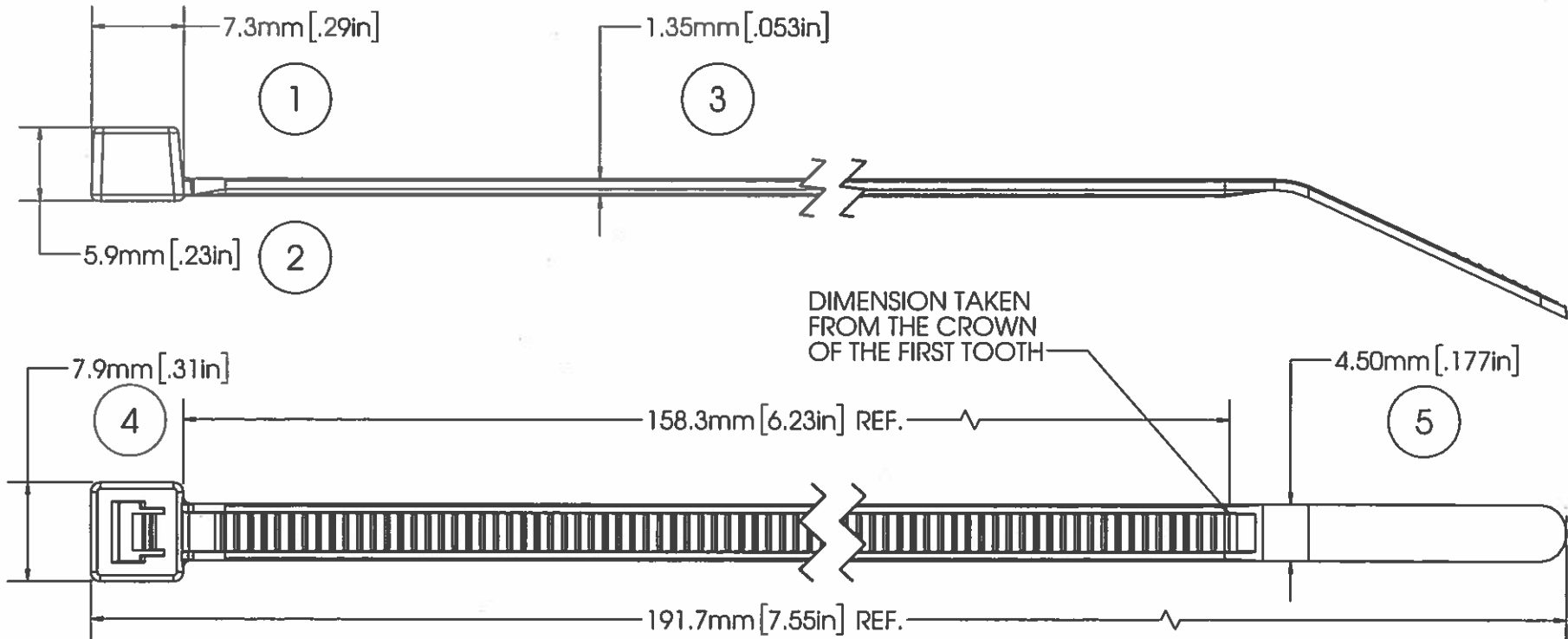

**NOTE:**

1. THESE CABLE TIES ARE PLENUM RATED AND HAVE A FLAMMABILITY RATING OF V-2
2. SPECIAL CHARACTERISTICS ARE NOTED BY A TRIANGLE ( Δ )



6	Δ FLAMMABILITY RATING:	HB RATED PER FMVSS302
7	Δ LOOP TENSILE STRENGTH:	50 LBF / 220N MIN. PER AS-23190
	OPERATING TEMP.:	-40°F (-40°C) TO 220°F (105°C)
	MIN. INSTALLATION TEMP.:	32°F (0°C)
	WEIGHT:	0.041 OZ./1.20 GRAMS
	BUNDLE DIAMETER:	1.59mm - 44.5mm
	TOOL:	12001 - HAND INSTALLATION TOOL 12500 - PNUEM. INSTALLATION TOOL
	TOOL TENSION SETTING:	6 - 8
	PACKAGING:	1000/BAG 5000/CASE

APPROVALS:	ENG. APPR.	<i>[Signature]</i> 10/12/16
	Q.A. APPR.	<i>Cattin Chellawala</i> 10/12/16



SPECIFIED TOLERANCES ARE:		MATERIAL	DESCRIPTION
.XX ± .03 IN.	.X ± .7 mm	NYLON 6/6, HEAT STABILIZED,	<b>7.5" CABLE TIE, STD</b>
.XXX ± .010 IN.	.XX ± .25 mm	COLOR	STOCK NO.
ANGULAR: ± 2°		<b>BLACK</b>	<b>08402-0</b>
			REV. <b>Q</b>

5

4

3

2

1